

# Indexable knives



# Contents



Grade recommendation and grade description

D4-D7

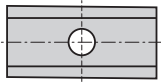

Indexable knives 35°

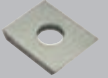

D8-D9



Indexable knives and scorers

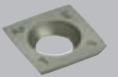

D10-D15

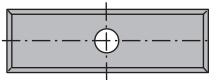

Indexable knives with 4 cutting edges

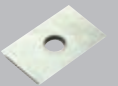

D16-D17

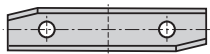

Indexable knives for slanting knives – bossed



D18-D21

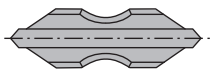

Scorers and centering points



D22

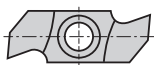

Grooving knives



D23

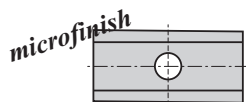

Indexable knives – soft wood 45°



D24-D26



Indexable knives and planer blades

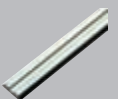

D27-D28



Chamfer breaking tips and chamfer knives



D29-D30

# Grade recommendation

**HDF**

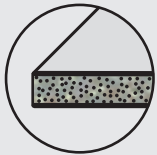

HC05	MG06	SMG02 KCR08	UMG04
------	------	----------------	-------

**Chipboard**



	UMG04 HC05 MG18	SMG02 MG06	KCR08
--	-----------------------	---------------	-------

**MDF**

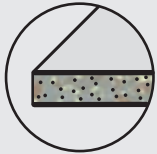

MG18	MG06 HC05	SMG02 KCR08	UMG04
------	--------------	----------------	-------

**Hardwood**



HC35	HC05 HC20	MG06 MG18	KCR08
------	--------------	--------------	-------

**Softwood**



HC20	HC35 HC05	MG18 KCR08	HE40
------	--------------	---------------	------

★	★★	★★★	★★★★★
Acceptable	Good	Very good	Optimum

**Service life – performance – surface quality** 

# Grade recommendations

## UMG04

ISO: K01

USA: -



**Composition:**  
Co 2.2%, WC balance,  
Other 0.6%

**Grain size:**  
Nano grain < 0.2 μm

**Transverse rupture strength:**  
3200 MPa  
464.000 P.S.I.

**Wear resistance**



**Hardness:**  
2500 HV10  
2400 HV30  
96.0 HRA

**Density:**  
15.3 g/cm<sup>3</sup>

**Fracture toughness K<sub>1C</sub>:**  
5.4 MPa.m<sup>-1/2</sup>



D4-D7

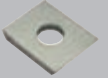

D8-D9

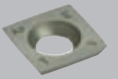

D10-D15

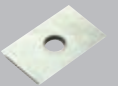

D16-D17



D18-D21



D22



D23

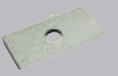

D24-D26

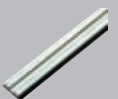

D27-D28



D29-D30

## SMG02

ISO: <K01

USA: -



**Composition:**  
Co 2.4%, WC balance,  
Other 0.44%

**Grain size:**  
Ultrafine grain 0.2 - < 0.5 μm

**Transverse rupture strength:**  
3500 MPa  
508.000 P.S.I.

**Wear resistance**



**Hardness:**  
2300 HV10  
2200 HV30  
95.2 HRA

**Density:**  
15.25 g/cm<sup>3</sup>

**Fracture toughness K<sub>1C</sub>:**  
5.7 MPa.m<sup>-1/2</sup>

## MG06

ISO: K01

USA: C4



**Composition:**  
Co 3.3%, WC balance,  
Other 0.62%

**Grain size:**  
Submicron grain 0.5 - < 0.8 μm

**Transverse rupture strength:**  
3300 MPa  
479.000 P.S.I.

**Wear resistance**



**Hardness:**  
2020 HV10  
1980 HV30  
93.9 HRA

**Density:**  
15.20 g/cm<sup>3</sup>

**Fracture toughness K<sub>1C</sub>:**  
6.5 MPa.m<sup>-1/2</sup>

## KCR08

ISO: -

USA: -



**Composition:**  
Co + Ni 4.2%, WC balance,  
Other 0.35%

**Grain size:**  
Submicron grain 0.5 - < 0.8 μm

**Transverse rupture strength:**  
2300 MPa  
334.000 P.S.I.

**Wear resistance**



**Hardness:**  
1920 HV10  
1885 HV30  
93.4 HRA

**Density:**  
15.20 g/cm<sup>3</sup>

**Fracture toughness K<sub>1C</sub>:**  
8.7 MPa.m<sup>-1/2</sup>



# Grade recommendations

**HC05**  
ISO: K10  
USA: C3

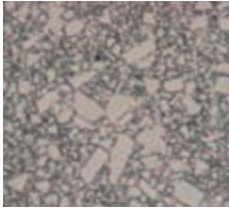

**Composition:**  
Co 4.0%, WC balance

**Grain size:**  
Fine grain 0.8 - < 1.3 μm

**Transverse rupture strength:**  
2200 MPa  
305.000 P.S.I.

**Hardness:**  
1730 HV10  
1700 HV30  
92.5 HRA

**Density:**  
15.15 g/cm<sup>3</sup>

**Fracture toughness K<sub>1C</sub>:**  
8.7 MPa.m<sup>-1/2</sup>

**Wear resistance**



**MG18**  
ISO: K20  
USA: C2

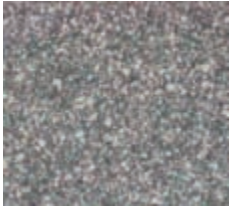

**Composition:**  
Co 10.0%, WC balance,  
Other 0.7%

**Grain size:**  
Submicron grain 0.5 - < 0.8 μm

**Transverse rupture strength:**  
3700 MPa  
537.000 P.S.I.

**Hardness:**  
1680 HV10  
1660 HV30  
92.3 HRA

**Density:**  
14.45 g/cm<sup>3</sup>

**Fracture toughness K<sub>1C</sub>:**  
9.4 MPa.m<sup>-1/2</sup>

**Wear resistance**



**HC20**  
ISO: K20  
USA: C2-C3

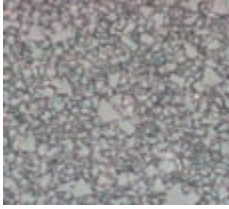

**Composition:**  
Co 6.0%, WC balance,  
Other 0.2%

**Grain size:**  
Fine grain 0.8 - < 1.3 μm

**Transverse rupture strength:**  
2200 MPa  
334.000 P.S.I.

**Hardness:**  
1640 HV10  
1620 HV30  
92.1 HRA

**Density:**  
15.00 g/cm<sup>3</sup>

**Fracture toughness K<sub>1C</sub>:**  
9.9 MPa.m<sup>-1/2</sup>

**Wear resistance**



**HC35**  
ISO: K30  
USA: C1



**Composition:**  
Co 9.0%, WC balance,

**Grain size:**  
Medium grain 1.3 - < 2.5 μm

**Transverse rupture strength:**  
2800 MPa  
335.000 P.S.I.

**Hardness:**  
1400 HV10  
1380 HV30  
90.3 HRA

**Density:**  
14.60 g/cm<sup>3</sup>

**Fracture toughness K<sub>1C</sub>:**  
10.9 MPa.m<sup>-1/2</sup>

**Wear resistance**

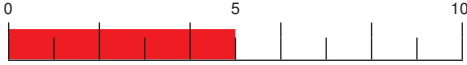

# Grade recommendations

## HE40

ISO: >K40

USA: -



**Composition:**  
Co + Ni + Fe 20.0%, WC balance

**Grain size:**  
Ultrafine grain 0.2 - < 0.5 μm

**Transverse rupture strength:**  
3500 MPa  
508.000 P.S.I.

**Hardness:**  
1250 HV10  
1240 HV30  
88.8 HRA

**Density:**  
13.15 g/cm<sup>3</sup>

**Fracture toughness K<sub>IC</sub>:**  
12.1 MPa.m<sup>-1/2</sup>

### Wear resistance

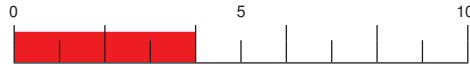

Grade designations for indexable knives, scorers and blanks

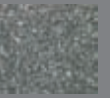

D4-D7

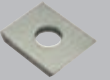

D8-D9

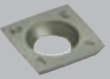

D10-D15

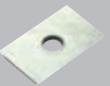

D16-D17



D18-D21



D22



D23



D24-D26

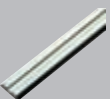

D27-D28



D29-D30

D7



# Indexable knives

## 35°

### CTK ST..

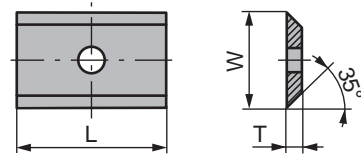

L [mm]	W [mm]	T [mm]	UMG04		SMG02		MG06		KCR08		HC05	
7.5	12.0	1.5					80239661	●	80360013	●	80330647	●
9.6	12.0	1.5			80358956	●	80239662	●	80360014	●	80330652	●
10.5	12.0	1.5							80360015	●	80239369	●
11.0	12.0	1.5							80360016	●	80239370	●
13.0	12.0	1.5							80360017	●	80239371	●
15.0	12.0	1.5			80358308	●	80239664	●	80360018	●	80330640	●
15.7	12.0	1.5							80360019	●	80239372	●
17.0	12.0	1.5							80360020	●	80331564	●
18.0	12.0	1.5							80360021	●	80239368	●
19.0	12.0	1.5							80360022	●	80331565	●
20.0	12.0	1.5	80358633	●	80330673	●	80239574	●	80358831	●	80330641	●
24.7	12.0	1.5					80358950	●	80360023	●	80239680	●

### CTK ST..

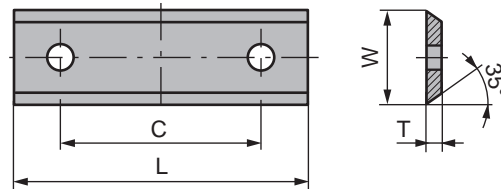

L [mm]	W [mm]	T [mm]	C [mm]	UMG04		SMG02		MG06		KCR08		HC05	
24.7	12.0	1.5	14					80358952	●	80360024	●	80239681	●
30.0	12.0	1.5	14	80358634	●	80330674	●	80239575	●	80358833	●	80330642	●
40.0	12.0	1.5	26	82009287	○	80358316	●	80239667	●	80360025	●	80330649	●
50.0	12.0	1.5	26	80358635	●	80330675	●	80239576	●	80358835	●	80330643	●
60.0	12.0	1.5	26			80358317	●	80239577	●	80360026	●	80330644	●



stock item



limited stock or upon request

# Indexable knives

35°

## CTK ST..

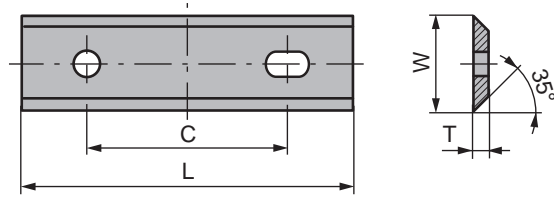

L [mm]	W [mm]	T [mm]	C [mm]	KCR08					
80.0	13.0	2.2	60	80360069	●				
100.0	13.0	2.2	60	80360084	●				
120.0	13.0	2.2	60	80360085	●				

## CTK ST..

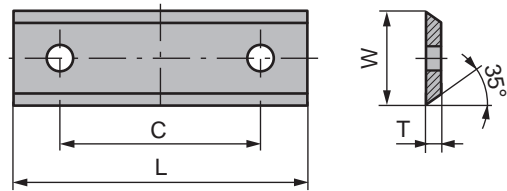

L [mm]	W [mm]	T [mm]	C [mm]	HC05	MG18				
30.0	12.0	2.5	14	82015043	●	82028333	○		

## CTK ST.. SH

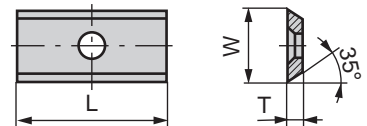
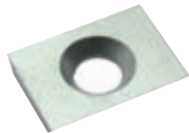

L [mm]	W [mm]	T [mm]	SMG02	HC20					
20.0	14.3	2.5	82030290	○	80239380	●			

● stock item

○ limited stock or upon request

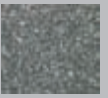

D4-D7

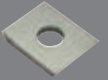

D8-D9

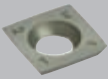

D10-D15

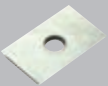

D16-D17



D18-D21



D22



D23



D24-D26

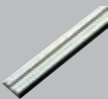

D27-D28



D29-D30

D9



# Indexable knives

## EcoKnives

# EcoKnives



- Best performance for best price
- First class CT carbide grades
- State of the art grinding quality
- Low weight, less centrifugal forces



hard material matters

PMW 08

# Indexable knives EcoKnives

## CTK ECO..

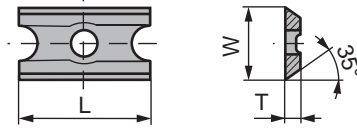

L [mm]	W [mm]	T [mm]	KCR08						
20.0	12.0	1.5	80359581	●					

## CTK ECO..

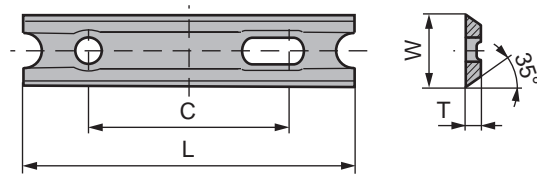

L [mm]	W [mm]	T [mm]	C [mm]	KCR08					
30.0	12.0	1.5	14	80359561	●				
50.0	12.0	1.5	26	80359562	●				



D4-D7

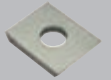

D8-D9

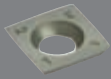

D10-D15

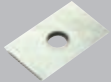

D16-D17



D18-D21



D22



D23



D24-D26

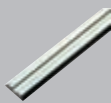

D27-D28



D29-D30

● stock item

○ limited stock or upon request



# Indexable knives

## Scorers

### CTK FC..

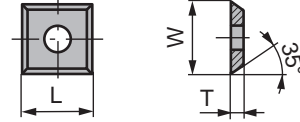
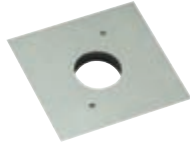

L [mm]	W [mm]	T [mm]	SMG02		MG06		KCR08		HC05	
10.5	10.5	1.5					80360027	●		
12.0	12.0	1.5	80358314	●	80239663	●	80360030	●	80330657	●
15.0	15.0	2.0					11235079	○		
17.0	17.0	2.0			80333665	●	80360028	●	80239386	●
19.0	19.0	2.0					80360029	●	80239387	●

### CTK SC..

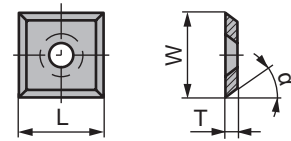

L [mm]	W [mm]	T [mm]	$\alpha$ [°]	SMG02		MG06		KCR08		HC05		MG18		HC20		HC35	
10.5	10.5	1.5	35									80330882	●				
13.0	13.0	2.5	30									80357494	○			82001035	○
13.4	13.4	1.5	30													80332547	●
13.6	13.6	2.0	45													80239418	●
14.0	14.0	1.2	30													80330669	●
14.0	14.0	1.7	30													80331749	●
14.0	14.0	2.0	30	80332539	●			80359802	●	80332394	●	80239725	●			80330668	●
14.3	14.3	2.5	35			82007207	○									80239421	●
14.6	14.6	2.5	30					11444230	○							80333743	○
15.0	15.0	2.5	30	82018721	○			82022498	○	82018719	○	82001124	○				
15.0	15.0	2.5	37							82018720	○						

● stock item

○ limited stock or upon request

# Indexable knives

## Scorers

### CTK SC..R

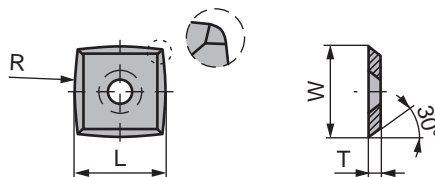

L [mm]	W [mm]	T [mm]	R [mm]	KCR08		HC05		MG18		HC35		HE40	
14.0	14.0	2.0	100							80359039	●	82009441	○
15.0	15.0	2.5	115	82019711	○	82003329	●	82023168	○				
15.0	15.0	2.5	150			11281810	○	11225484	●				

### CTK FC.. CB

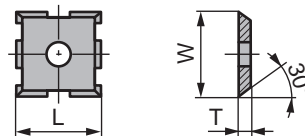

L [mm]	W [mm]	T [mm]	MG18							
15.0	15.0	2.0	80239392	○						

### CTK FC.. CB/SH

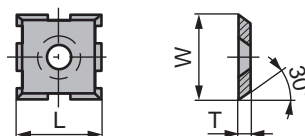

L [mm]	W [mm]	T [mm]	MG18							
15.0	15.0	2.0	82009817	○						



D4-D7

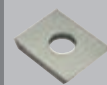

D8-D9

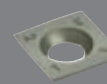

D10-D15



D16-D17



D18-D21



D22

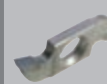

D23



D24-D26

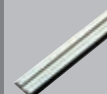

D27-D28



D29-D30

● stock item

○ limited stock or upon request



# Indexable knives

## Scorers

### CTK GR..

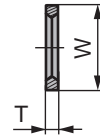
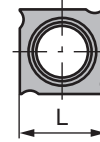

L [mm]	W [mm]	T [mm]	HC20						
14.0	14.0	2.0	80359032	●					
14.0	14.0	2.5	80332764	●					
14.0	14.0	3.0	80359033	●					
18.0	18.0	1.95	80330658	●					
18.0	18.0	2.5	80330659	●					
18.0	18.0	2.95	80331492	●					
18.0	18.0	3.7	80239391	●					
18.0	18.0	4.0	80331493	●					

### CTK SC.. 3CUT

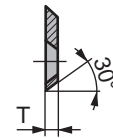
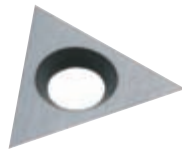

L [mm]	T [mm]	MG18							
22.0	2.0	80239466	●						

### CTK SC.. RHO

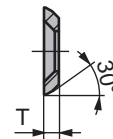
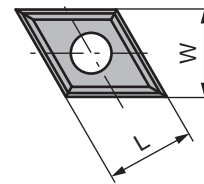
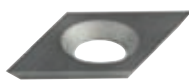

L [mm]	W [mm]	T [mm]	HC05						
14.0	14.0	2.0	80332377	●					

● stock item

○ limited stock or upon request

# Indexable knives Scorers

## CTK SC..

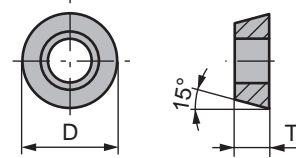

D [mm]	T [mm]	MG06						
11.0	4.0	11335391	●					



D4-D7

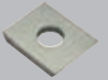

D8-D9

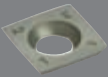

D10-D15

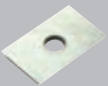

D16-D17



D18-D21



D22



D23



D24-D26

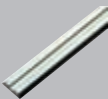

D27-D28



D29-D30



stock item



limited stock or upon request



# Indexable knives

## 4 cutting edges

### CTK FC..

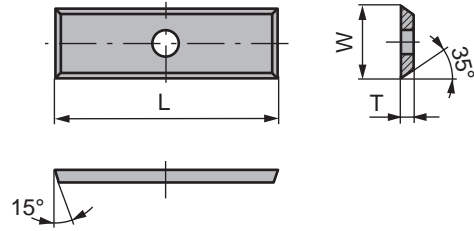
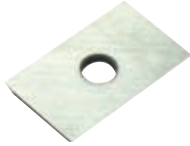

L [mm]	W [mm]	T [mm]	SMG02		MG06		HC05	
9.0	12.0	1.5					80239376	●
10.0	12.0	1.5					80239374	●
19.5	12.0	1.5	80359075	●	80359053	●		

### CTK FC..

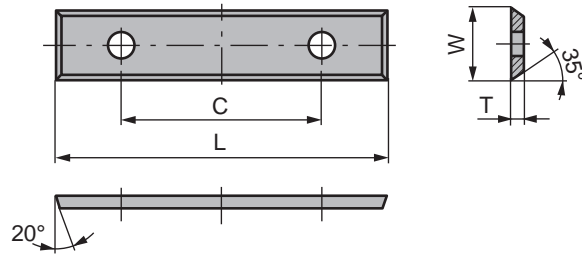

L [mm]	W [mm]	T [mm]	C [mm]	UMG04		SMG02		MG06		KCR08		HC05	
29.0	12.0	1.5	14									80330711	●
29.5	9.0	1.5	14					80359055	●	80360081	○	80331173	●
29.5	12.0	1.5	14	80359079	●	80359076	●	80359054	●	80360082	○	80331886	●
49.5	9.0	1.5	26					80359056	●	80360083	○	80359034	●
49.5	12.0	1.5	26	80359080	●	80359077	●	80359057	●	80360089	○	80331887	●
59.5	12.0	1.5	26			80359078	●	80359058	●			80359035	●

● stock item

○ limited stock or upon request

# Indexable knives

## 4 cutting edges

### CTK ECO.. FC

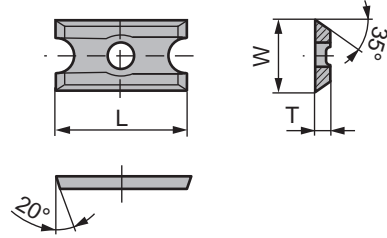

L [mm]	W [mm]	T [mm]	KCR08						
19.5	12.0	1.5	11507903	○					

### CTK ECO.. FC

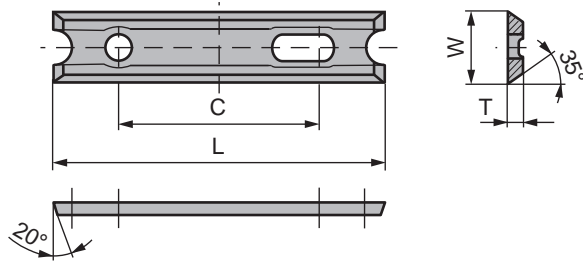

L [mm]	W [mm]	T [mm]	C [mm]	KCR08					
29.5	12.0	1.5	14	11507905	○				
49.5	12.0	1.5	26	11507910	○				

### CTK FC.. 3H

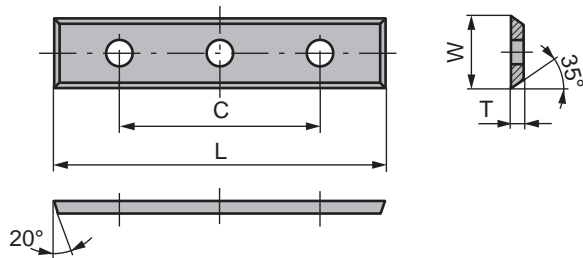

L [mm]	W [mm]	T [mm]	C [mm]	SMG02	MG06	KCR08	HC05				
50.0	12.0	1.7	37	82004411	○	80359059	●	80358958	●	80419334	●



D4-D7



D8-D9

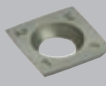

D10-D15

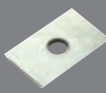

D16-D17



D18-D21



D22



D23



D24-D26



D27-D28



D29-D30

● stock item

○ limited stock or upon request





# Indexable knives

## Indexable knives for slanting knives - bossed

**CTK SK.. RI.. °**



L [mm]	W [mm]	T [mm]	MG06	KCR08	HC05			
19.5	12.0	1.5	80359069	○	80360075	○	80239366	●

**CTK SK.. LE.. °**



L [mm]	W [mm]	T [mm]	MG06	KCR08	HC05			
19.5	12.0	1.5	80359070	○	80360076	○	80239367	●

● stock item      ○ limited stock or upon request

# Indexable knives

## Indexable knives for slanting knives - bossed

### CTK SK.. RI.. °

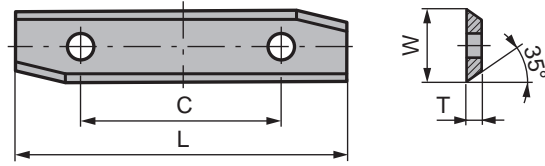

L [mm]	W [mm]	T [mm]	C [mm]	MG06		KCR08		HC05	
29.5	12.0	1.5	14	80359064	○	80360070	○	80239365	●
49.5	12.0	1.5	26	80359066	○	80360072	○	80359037	●

### CTK SK.. LE.. °

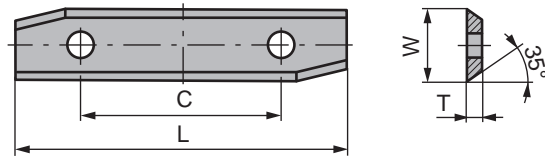

L [mm]	W [mm]	T [mm]	C [mm]	MG06		KCR08		HC05	
29.5	12.0	1.5	14	80359065	○	80360071	○	80330648	●
49.5	12.0	1.5	26	80359067	○	80360073	○	80359036	●



D4-D7

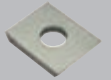

D8-D9

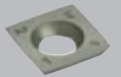

D10-D15

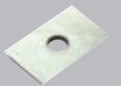

D16-D17

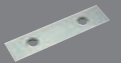

D18-D21



D22



D23



D24-D26

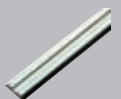

D27-D28



D29-D30

● stock item

○ limited stock or upon request



# Indexable knives

## Indexable knives for slanting knives - bossed

### CTK SK.. RI..°

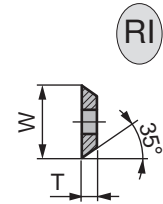
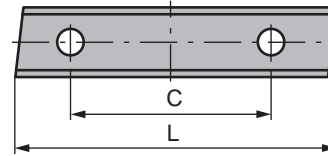

L [mm]	W [mm]	T [mm]	C [mm]	MG06		KCR08		HC05		
29.5	12.0	1.5	14	80359071	○	80360078	○	80330645	●	
49.5	12.0	1.5	26	80359073	○	80360080	○	80239360	●	

### CTK SK.. LE..°

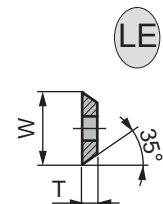
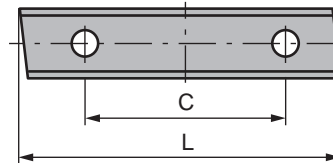

L [mm]	W [mm]	T [mm]	C [mm]	MG06		KCR08		HC05		
29.5	12.0	1.5	14	80359072	○	80360077	○	80330646	●	
49.5	12.0	1.5	26	80359074	○	80360079	○	80239361	●	



stock item



limited stock or upon request

# Indexable knives

## Indexable knives for slanting knives - bossed

### CTK ST.. BO

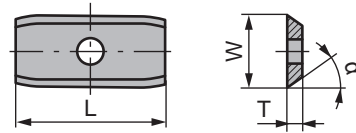

L [mm]	W [mm]	T [mm]	$\alpha$ [°]	HC05					
20.0	12.0	1.5	35	80359038	●				
24.0	12.0	1.5	40	82000067	○				
24.7	12.0	1.5	40	80334040	○				

### CTK ST.. BO

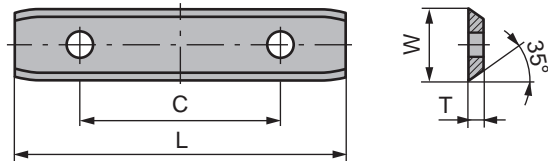

L [mm]	W [mm]	T [mm]	C [mm]	HC05					
30.0	12.0	1.5	14	80357890	●				
40.0	12.0	1.5	26	82018841	○				
50.0	12.0	1.5	26	80357892	●				



D4-D7

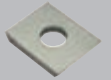

D8-D9

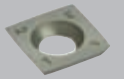

D10-D15

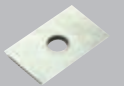

D16-D17

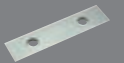

D18-D21



D22



D23

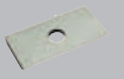

D24-D26

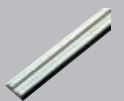

D27-D28



D29-D30

● stock item

○ limited stock or upon request



# Indexable knives

## Scorers and centering points

### CTK SC..

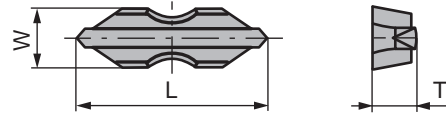

L [mm]	W [mm]	T [mm]	Material	Stock Status	Other	Other	Other	Other
18.0	6.0	3.5	HC20	●				

### CTK CP..

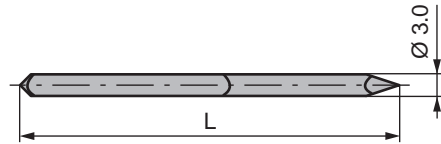

L [mm]	Material	Stock Status	Other	Other	Other	Other	Other
33.5	HC35	●					

● stock item

○ limited stock or upon request

# Indexable knives

## Grooving knives

### CTK GR..

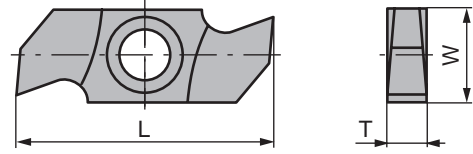

L [mm]	W [mm]	T [mm]	HC35						
34.0	16.0	3.2	80239830	●					
34.0	16.0	4.0	80239831	●					
34.0	16.0	5.0	80239832	●					

### CTK GR..

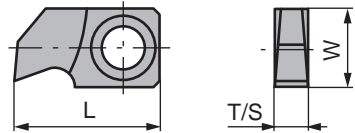

L [mm]	W [mm]	T [mm]	S [mm]	MG18					
24.5	13.0	5.0	4.0	80357834	●				
24.5	13.0	5.0	5.0	80358124	●				



D4-D7

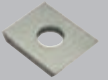

D8-D9

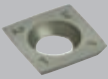

D10-D15

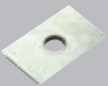

D16-D17



D18-D21



D22



D23



D24-D26

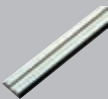

D27-D28



D29-D30

● stock item

○ limited stock or upon request



# Indexable knives

## Soft wood 45°

### CTK ST.. 45°



45°

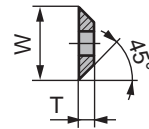
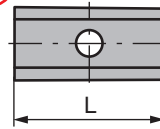

L [mm]	W [mm]	T [mm]	MG18						
7.5	12.0	1.5	80330520	●					
15.0	12.0	1.5	80330522	●					
20.0	12.0	1.5	80330523	●					
24.7	12.0	1.5	80332389	●					

### CTK ST.. 45°



45°

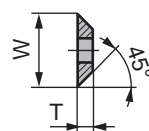
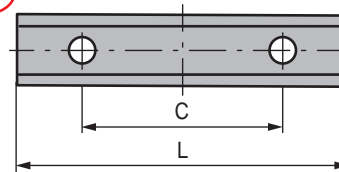

L [mm]	W [mm]	T [mm]	C [mm]	MG18					
30.0	12.0	1.5	14	80330524	●				
40.0	12.0	1.5	26	80330525	●				
50.0	12.0	1.5	26	80330526	●				
60.0	12.0	1.5	26	80330527	●				

### CTK FC.. 45°

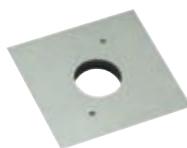

45°

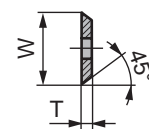
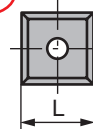

L [mm]	W [mm]	T [mm]	MG18						
12.0	12.0	1.5	80330521	●					

● stock item

○ limited stock or upon request

# Indexable knives

## Soft wood 45° and microfinish

### CTK ST.. MIC45°

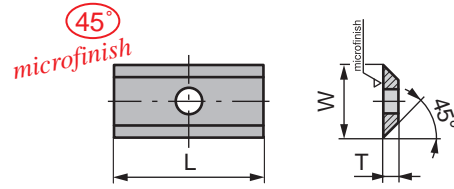

L [mm]	W [mm]	T [mm]	MG18		HE40				
9.6	12.0	1.5	80359051	●	80359044	○			
15.0	12.0	1.5	80330537	●	80359045	○			
20.0	12.0	1.5	80330538	●	80357973	○			

### CTK ST.. MIC45°

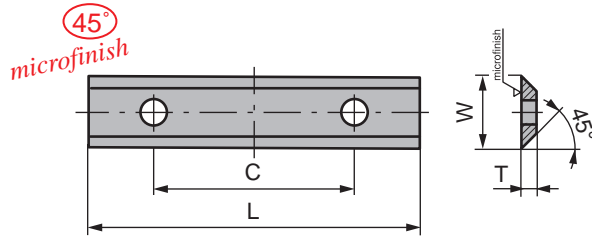

L [mm]	W [mm]	T [mm]	C [mm]	MG18		HE40				
30.0	12.0	1.5	14	80330539	●	80357974	○			
40.0	12.0	1.5	26	80330540	●	80359046	○			
50.0	12.0	1.5	26	80330541	●	80357975	○			
60.0	12.0	1.5	26	80330542	●	80359047	○			

### CTK ST.. MIC45°

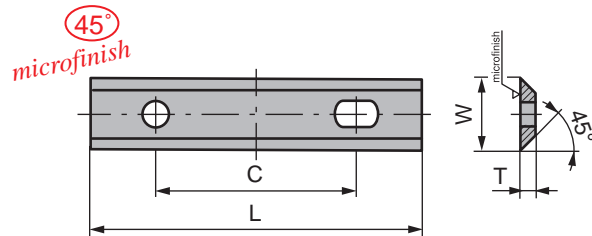

L [mm]	W [mm]	T [mm]	C [mm]	MG18		HE40				
80.0	13.0	2.2	60	80359052	●	80359048	○			

● stock item

○ limited stock or upon request



D4-D7

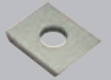

D8-D9

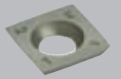

D10-D15

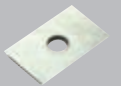

D16-D17



D18-D21



D22



D23

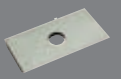

D24-D26

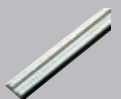

D27-D28



D29-D30

D25



# Indexable knives

## Soft wood 45° and microfinish

### CTK FC.. MIC45°

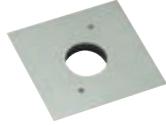

45°  
microfinish

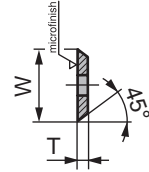
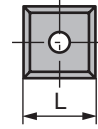

L [mm]	W [mm]	T [mm]	MG18	HE40				
12.0	12.0	1.5	80330536	●	80359049	○		

### CTK SC.. MIC

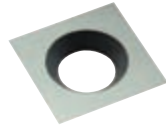

microfinish

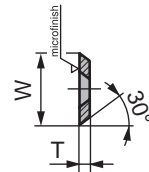
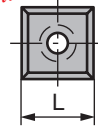

L [mm]	W [mm]	T [mm]	MG18	HE40				
14.0	14.0	2.0	80332257	●	80359050	○		

### CTK ST.. CB



with chip breaker

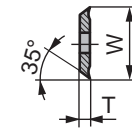
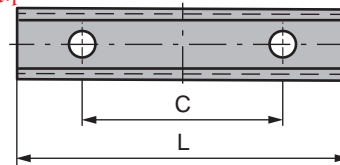

L [mm]	W [mm]	T [mm]	C [mm]	HE40				
20.0	12.0	1.5	0	80357984	○			
30.0	12.0	1.5	14	80357985	○			
50.0	12.0	1.5	26	80357986	○			

● stock item

○ limited stock or upon request

# Indexable knives

## CTK MK..FG

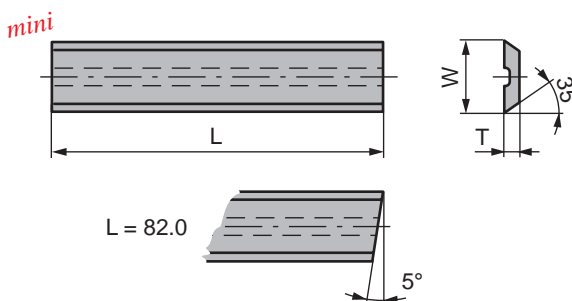

L = 82.0

L [mm]	W [mm]	T [mm]	HC05	HC35				
12.0	5.5	1.1	80330662	●				
20.0	5.5	1.1	80330660	●				
30.0	5.5	1.1	80331568	●				
40.0	5.5	1.1	80330661	●				
50.0	5.5	1.1	80239396	●				
60.0	5.5	1.1	80359040	●				
82.0	5.1	1.2			80332270	●		

## CTK MK..BG

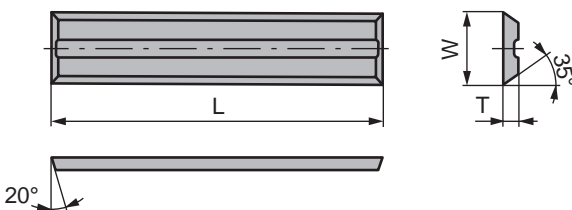

L [mm]	W [mm]	T [mm]	HC05					
12.0	5.5	1.1	80239398	●				

## CTK MK..BCG

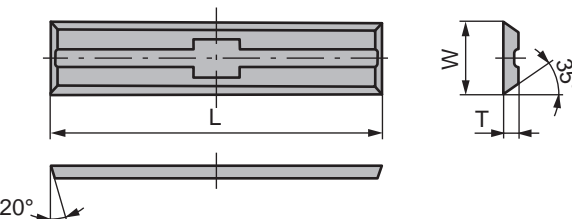

L [mm]	W [mm]	T [mm]	MG06	HC05				
20.0	4.1	1.1	80359060	●	80331404	●		
20.0	5.5	1.1	80359061	●	80331406	●		
25.0	5.5	1.1	80359062	●	80331408	●		
30.0	5.5	1.1	80332194	●	80331407	●		
40.0	5.5	1.1	80359063	●	80331381	●		
50.0	5.5	1.1	80332193	●	80331409	●		

● stock item

○ limited stock or upon request



D4-D7

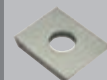

D8-D9

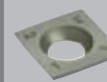

D10-D15



D16-D17



D18-D21



D22



D23

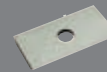

D24-D26

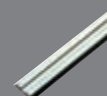

D27-D28



D29-D30



D27

# Indexable knives

## Planer blades

### CTK PK..

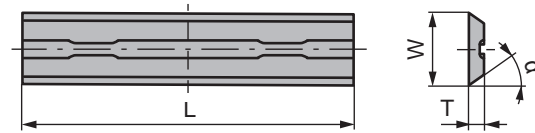

L [mm]	W [mm]	T [mm]	$\alpha$ [°]	HC35	
56.0	5.5	1.1	35	80333440	● Adler
75.0	5.5	1.1	35	80330664	● AEG / Bosch / Festo / Haffner / Holz-Her / Kress / Mafell / Metabo / Scheer / Skil
78.0	5.5	1.1	35	80331436	●
80.5	5.9	1.2	40	80330666	● ELU
82.0	5.5	1.1	35	80330665	● AEG / Fein / Haffner / Hitachi / Mafell / Makita / Metabo / Bosch / Black&Decker / Felisatti / Holz-Her / Peugeot / Ryobi / Skil
92.0	5.5	1.2	35	80332144	● Bosch / Black&Decker / Hitachi / Ryobi
102.0	5.5	1.1	35	80239410	● Black&Decker / AEG



stock item



limited stock or upon request

# Indexable knives

## Chamfer breaking tips and chamfer knives

### CTK CH.. 45°

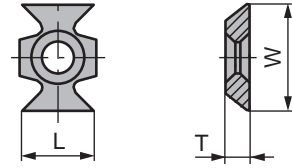

L [mm]	W [mm]	T [mm]	HC20						
16.0	22.0	5.0	80330575	●					

### CTK CH.. R

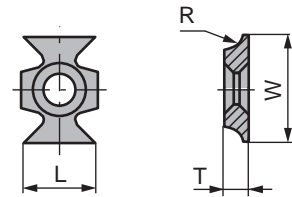

L [mm]	W [mm]	T [mm]	R [mm]	HC20					
16.0	22.0	5.0	1.0	80359041	●				
16.0	22.0	5.0	1.5	80330576	●				
16.0	22.0	5.0	2.0	80330577	●				
16.0	22.0	5.0	2.5	80330579	●				
16.0	22.0	5.0	3.0	80330578	●				
16.0	22.0	5.0	5.0	80333980	●				
16.0	22.0	5.0	6.0	80359042	●				



D4-D7

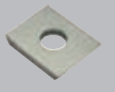

D8-D9

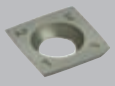

D10-D15

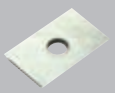

D16-D17



D18-D21



D22



D23



D24-D26

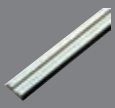

D27-D28



D29-D30

D29

● stock item

○ limited stock or upon request



# Indexable knives

## Chamfer breaking tips and chamfer knives

### CTK CH.. RI/LE

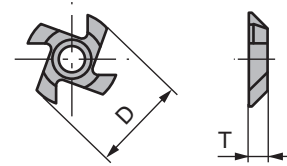

	D [mm]	T [mm]	HC20						
RI	25.0	5.0	80239423	●					
LE	25.0	5.0	80239424	●					

### CTK CH..

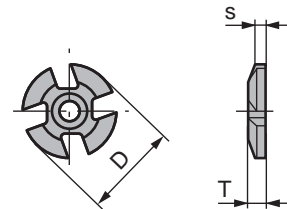

D [mm]	T [mm]	S [mm]	HC20						
25.0	4.6	2.8	80239567	●					

● stock item

○ limited stock or upon request